



MAINETTI
trasformatori

	Pag.
Trasformatori monofase di comando	3
Trasformatori monofase a colonna	4
Trasformatori monofase di isolamento	5
Trasformatori monofase di sicurezza	6
Trasformatori monofase di sicurezza IP67	7
Trasformatori monofase modulari	8
Trasformatori di isolamento a uso elettromedicale	9
Autotrasformatori monofase	10
Trasformatori trimonofase	11
Trasformatori trifase	12
Trasformatori trifase per impianti fotovoltaici	13
Autotrasformatori trifase	14
Reattanze trifase	15
Armadi di contenimento	16



TRASFORMATORI MONOFASE DI COMANDO

T1

SINGLE PHASE CONTROL TRANSFORMERS



Trasformatori con tensione fino a 1000V
 Impregnati in resina
 Avvolgimenti in rame cl.H
 A richiesta schermo elettrostatico
 Isolamento cl.B a richiesta cl.F
 Morsetto di terra
 Morsetti di nostro brevetto indicanti tipo di tensione
 tramite codice colori
 Tensione di isolamento 3,5 KV
 A richiesta sonde termiche
 Frequenza 50-60Hz
 Servizio continuo
 A richiesta tropicalizzati
 A richiesta morsetto portafusibile
 Ogni trasformatore è testato singolarmente e
 corredato di scheda tecnica

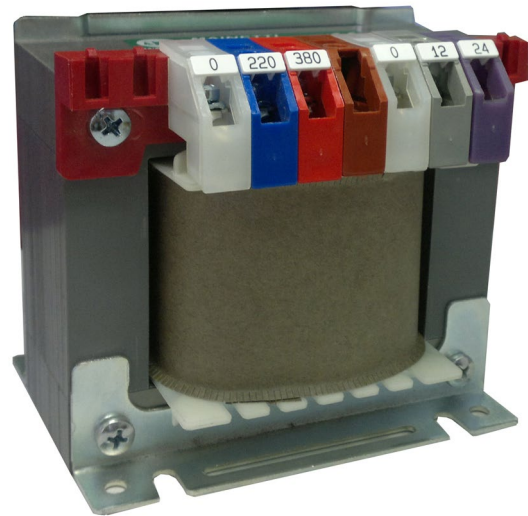

*Transformers with voltage up to 1000V
 Resin insulation
 Winding in copper class H
 Electric shield on request
 Insulation class B, class F on request
 Ground terminal
 Terminal of our patent that identify the different
 voltage by a colour code.
 Insulation voltage 3,5 KV
 Thermal probe on request
 Frequency 50-60 Hz
 Continuous service
 Tropicalized on request
 Terminal with fuse on request
 Every transformer is tested and sell with data sheet*

**NORME CEI EN 61558 2-2
 EUROPEAN STANDARD EN 61558 2-2**

POTENZA		DIMENSIONI		FORI		FISSAGGIO	PESO
POWER		DIMENSION		FIXING		HOLES	WEIGHT
VA	L	P	H	A	B		Kg
30	68	80	60	45	55		1,0
50	75	80	66	55	55		1,2
60	75	95	66	5	60		1,3
80	84	90	75	60	60		1,6
100	96	87	90	85	54		2,3
160	96	105	90	85	72		3,1
200	96	115	90	85	82		3,5
250	120	105	110	104	65		3,9
315	120	110	110	104	75		4,9
350	120	115	110	104	80		5,5
400	120	125	110	104	85		5,7
450	120	130	110	104	90		6,0
500	120	140	110	104	95		6,5
550	120	145	110	104	100		7,0
630	150	115	135	132	72		7,5
800	150	135	135	132	82		9,2
1000	150	145	135	132	102		12
1200	192	140	205	145	95		13
1500	192	150	205	145	105		15
2000	192	165	205	145	120		22
2500	192	185	205	145	140		24

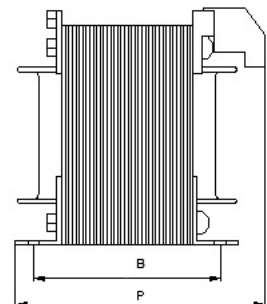
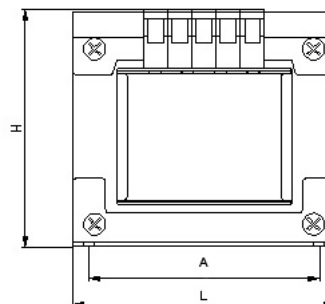

MAINETTI
 trasformatori

Via Verziano, 4 Tel.0302681112
 25131 Brescia
 email : info@mainetti.it
 mainettitransformatori@pec.it
 web : www.mainetti.it

TRASFORMATORI MONOFASE A COLONNA

T2

SINGLE PHASE CORE TYPE TRANSFORMERS



Trasformatori con tensione fino a 1000V
 Impregnati in resina
 Avvolgimenti in rame cl.H
 A richiesta schermo elettrostatico
 Isolamento cl.B a richiesta cl.F
 Morsetto di terra
 Morsetti di nostro brevetto
 Tensione di isolamento 3,5 KV
 A richiesta sonde termiche
 Frequenza 50-60Hz
 Servizio continuo
 A richiesta tropicalizzati
 A richiesta morsetto portafusibile
 Ogni trasformatore è testato singolarmente e
 corredato di scheda tecnica

*Transformers with voltage up to 1000V
 Resin insulation
 Winding in copper class H
 Electric shield on request
 Insulation class B, class F on request
 Ground terminal
 Terminal of our patent
 Insulation voltage 3,5 KV
 Thermal probe on request
 Frequency 50-60 Hz
 Continuous service
 Tropicalized on request
 Terminal with fuse on request
 Every transformer is tested and sell with data sheet*



**NORME CEI EN 61558 2-2
 EUROPEAN STANDARD EN 61558 2-2**

POTENZA		DIMENSIONI			FORI		FISSAGGIO	PESO
POWER		DIMENSION			FIXING	HOLES		WEIGHT
VA	L	P	H	A	B	Kg		
3500	240	210	310	205	125	28		
4000	240	230	310	205	140	31		
5000	240	240	310	205	150	34		
6300	240	250	310	205	160	38		
8000	240	270	310	205	180	41		
10000	240	290	310	205	200	46		
12500	320	220	410	280	170	62		
13000	320	220	410	280	170	62		
16000	320	230	410	280	190	74		
20000	320	250	410	280	210	85		

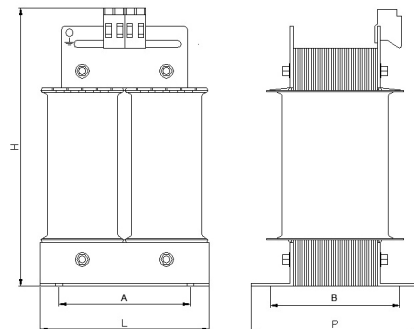

MAINETTI
 trasformatori

Via Verzano, 4 Tel.0302681112
 25131 Brescia
 email : info@mainetti.it
 mainettitrasformatori@pec.it
 web : www.mainetti.it

TRASFORMATORI MONOFASE DI ISOLAMENTO

TI

SINGLE PHASE ISOLATING TRANSFORMERS

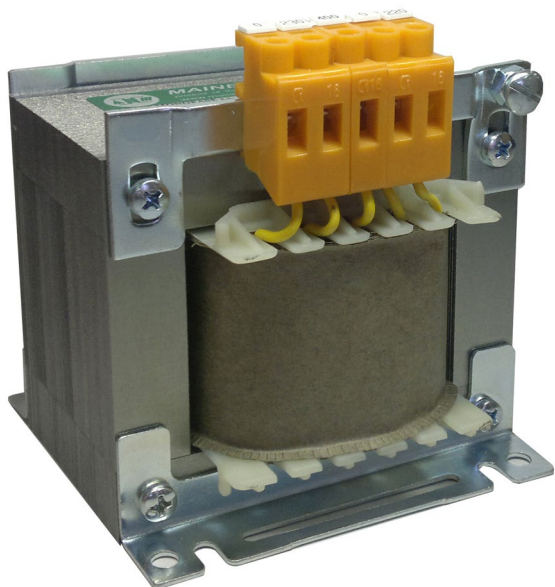

**NORME CEI EN 61558 2-4 a richiesta IS365
EUROPEAN STANDARD EN 61558 2-4**

Trasformatori con tensione fino a 1000V
 Impregnati in resina
 Avvolgimenti in rame cl.H
 A richiesta schermo elettrostatico
 Isolamento cl.B a richiesta cl.F
 Morsetto di terra
 Tensione di isolamento 4 KV
 A richiesta sonde termiche
 Frequenza 50-60Hz
 Servizio continuo
 A richiesta tropicalizzati
 A richiesta morsetto portafusibile
 Ogni trasformatore è testato singolarmente e
 corredato di scheda tecnica
 A richiesta norme IS365 per applicazioni ferroviarie

*Transformers with voltage up to 1000V
 Resin insulation
 Winding in copper class H
 Electric shield on request
 Insulation class B, class F on request
 Ground terminal.
 Insulation voltage 4 KV
 Thermal probe on request
 Frequency 50-60 Hz
 Continuous service
 Tropicalized on request
 Terminal with fuse on request
 Every transformer is tested and sell with data sheet
 On request standard IS365 for railways application*

POTENZA	DIMENSIONI			FORI	FISSAGGIO	PESO
POWER	DIMENSION			FIXING	HOLES	WEIGHT
VA	L	P	H	A	B	Kg
30	68	80	60	45	55	1,0
50	75	80	66	55	55	1,2
60	75	95	66	5	60	1,3
80	84	90	75	60	60	1,6
100	96	87	90	85	54	2,3
160	96	105	90	85	72	3,1
200	96	115	90	85	82	3,5
250	120	105	110	104	65	3,9
315	120	110	110	104	75	4,9
350	120	115	110	104	80	5,5
400	120	125	110	104	85	5,7
450	120	130	110	104	90	6,0
500	120	140	110	104	95	6,5
550	120	145	110	104	100	7,0
630	150	115	135	132	72	7,5
800	150	135	135	132	82	9,2
1000	150	145	135	132	102	12
1200	192	140	205	145	95	13
1500	192	150	205	145	105	15
2000	192	165	205	145	120	22
2500	192	185	205	145	140	24
3000	192	190	205	145	155	26
3500	240	210	310	205	125	28
4000	240	230	310	205	140	31
5000	240	240	310	205	150	34
6300	240	250	310	205	160	38
8000	240	270	310	205	180	41
10000	240	290	310	205	200	46
12500	320	220	410	280	170	62
13000	320	220	410	280	170	62
16000	320	230	410	280	190	74
20000	320	250	410	280	210	85

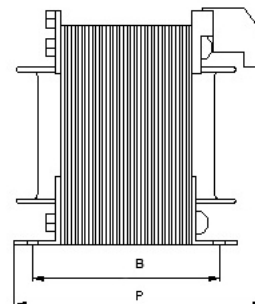
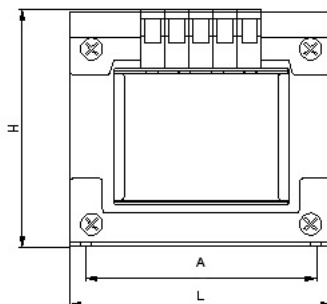

MAINETTI
trasformatori

Via Verziano, 4 Tel.0302681112
 25131 Brescia
 email : info@mainetti.it
 mainettitrasformatori@pec.it
 web : www.mainetti.it

TRASFORMATORI MONOFASE DI SICUREZZA

TS

SINGLE PHASE SAFETY ISOLATING TRANSFORMERS



Trasformatori con tensione primaria fino a 1000V
 e secondaria fino a 50V
 Impregnati in resina
 Avvolgimenti in rame cl.H
 A richiesta schermo elettrostatico
 Isolamento cl.B a richiesta cl.F
 Morsetto di terra
 Tensione di isolamento 4 KV
 A richiesta sonde termiche
 Frequenza 50-60Hz
 Servizio continuo
 A richiesta tropicalizzati
 A richiesta morsetto portafusibile
 Ogni trasformatore è testato singolarmente e
 corredato di scheda tecnica

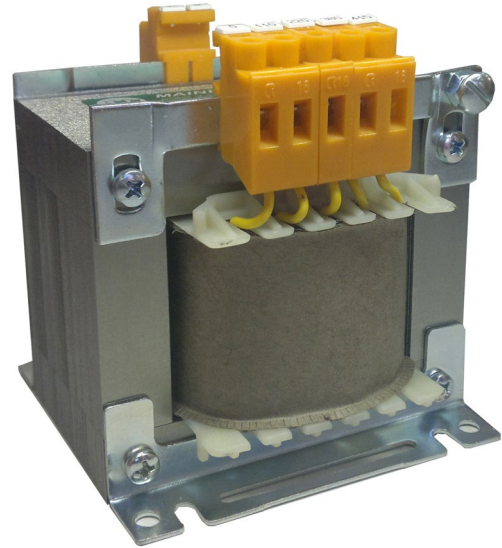

*Transformers with primary voltage up to 1000V
 and secondary voltage up to 50V
 Resin insulation
 Winding in copper class H
 Electric shield on request
 Insulation class B, class F on request
 Ground terminal
 Insulation voltage 4 KV
 Thermal probe on request
 Frequency 50-60 Hz
 Continuous service
 Tropicalized on request
 Terminal with fuse on request
 Every transformer is tested and sell with data sheet*

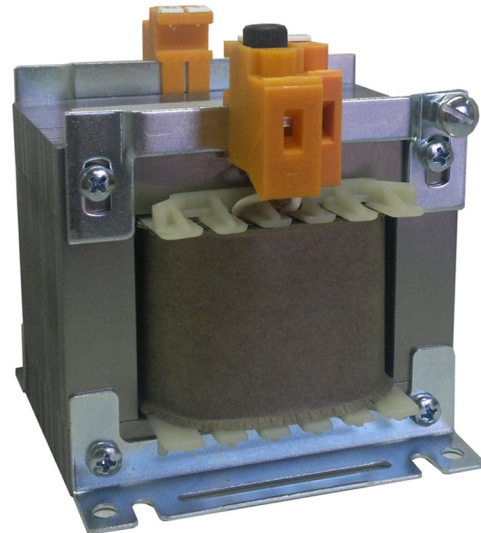

POTENZA		DIMENSIONI			FORI		FISSAGGIO		PESO
POWER		DIMENSION			FIXING		HOLES		WEIGHT
VA	L	P	H	A	B			Kg	
50	75	80	66	55	55			1,2	
100	96	87	90	85	54			2,3	
160	96	105	90	85	72			3,1	
200	96	115	90	85	82			3,5	
250	120	105	110	104	65			3,9	
315	120	110	110	104	75			4,9	
350	120	115	110	104	80			5,5	
400	120	125	110	104	85			5,7	
450	120	130	110	104	90			6,0	
500	120	140	110	104	95			6,5	
550	120	145	110	104	100			7,0	
630	150	115	135	132	72			7,5	
800	150	135	135	132	82			9,2	
1000	150	145	135	132	102			12	
1200	192	140	205	145	95			13	
1500	192	150	205	145	105			15	
2000	192	165	205	145	120			22	
2500	192	185	205	145	140			26	
3000	192	190	205	145	155			28	
3500	240	210	310	205	125			31	
4000	240	230	310	205	140			32	
5000	240	240	310	205	150			34	
6300	240	240	310	205	160			38	

**NORME CEI EN 61558 2-6
 EUROPEAN STANDARD EN 61558 2-6**

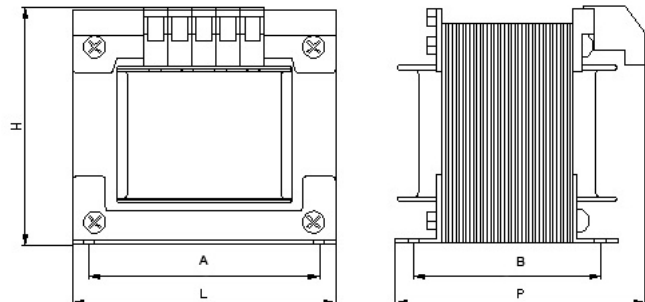

MAINETTI
 trasformatori

Via Verziano, 4 Tel.0302681112
 25131 Brescia
 email : info@mainetti.it
 mainettitrasformatori@pec.it
 web : www.mainetti.it

TRASFORMATORI MONOFASE DI SICUREZZA IP67

IP67

SINGLE PHASE SAFETY TRANSFORMERS IP67



Trasformatori in contenitore impregnati in resina epossidica
 Ingresso e uscita tramite appositi cavi
 Avvolgimenti in rame cl.H
 Isolamento cl.F
 Trasformatori in classe II
 Tensione di isolamento 4 KV
 Frequenza 50-60Hz
 Grado di protezione IP67
 Servizio continuo
 Ogni trasformatore è testato singolarmente e corredato di scheda tecnica



*Transformers in container impregnated in epoxy resin
 Input and output with cable
 Winding in copper class H
 Insulation class F
 Transformers class II
 Insulation voltage 4 KV
 Frequency 50-60 Hz
 Protection grade IP67
 Continuous service
 Every transformer is tested and sell with data sheet*

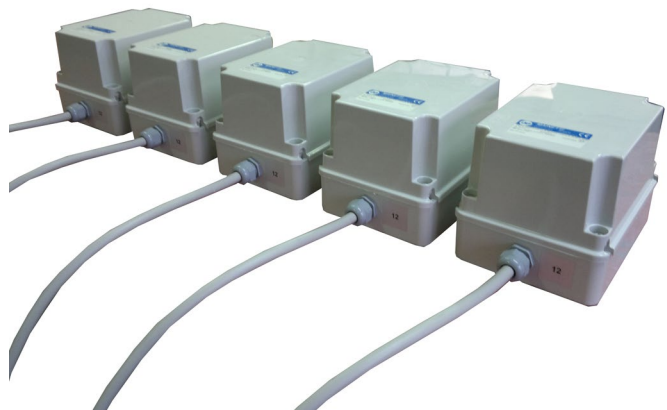

**NORME CEI EN 61558 2-6
 EUROPEAN STANDARD EN 61558 2-6**

POTENZA		DIMENSIONI			PESO
POWER		DIMENSION			WEIGHT
VA	L	P	H	Kg	
100	160	150	120	5	
200	160	150	120	6	
300	200	150	150	7,5	
400	200	150	150	8,5	
500	200	150	150	10	
600	250	170	200	12	
800	250	170	200	14	

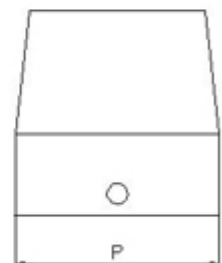
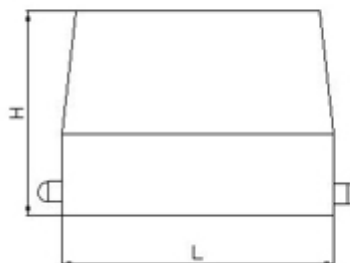

MAINETTI
 trasformatori

Via Verziano, 4 Tel.0302681112
 25131 Brescia
 email : info@mainetti.it
 mainettitrasformatori@pec.it
 web : www.mainetti.it

TRASFORMATORI MONOFASE MODULARI

DIN

SINGLE PHASE TRANSFORMERS FOR DIN MOUNTING

Trasformatori con tensione fino a 1000V
 Impregnati in resina
 Avvolgimenti in rame cl.H
 A richiesta schermo elettrostatico
 Isolamento cl.B a richiesta cl.F
 Trasformatori in contenitore da 4 moduli di nostra
 progettazione per fissaggio su guida DIN
 Tensione di isolamento 3,5 KV
 Frequenza 50-60Hz
 Servizio continuo
 Ogni trasformatore è testato singolarmente e
 corredato di scheda tecnica

*Transformers with voltage up to 1000V
 Resin insulation
 Winding in copper class H
 Electric shield on request
 Insulation class B, class F on request
 Transformers in box for DIN rail mounting (4module)
 Insulation voltage 3,5 KV
 Frequency 50-60 Hz
 Continuous service
 Every transformer is tested and sell with data sheet*



**NORME CEI EN 61558 2-4
 EUROPEAN STANDARD EN 61558 2-4**

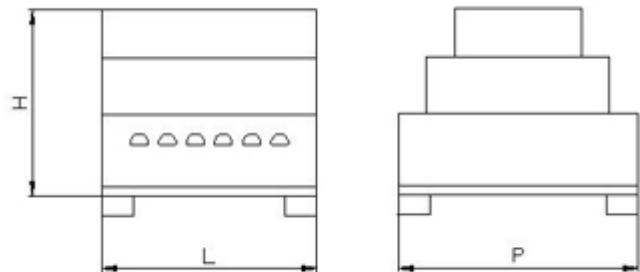

POTENZA		DIMENSIONI		FORI	FISSAGGIO	PESO
POWER		DIMENSION		FIXING	HOLES	WEIGHT
VA	L	P	H	A	B	Kg
30	75	80	85			0,9
50	75	80	85			1



MAINETTI
trasformatori

Via Verziano, 4 Tel.0302681112
 25131 Brescia
 email : info@mainetti.it
 mainettitrasformatori@pec.it
 web : www.mainetti.it

TRASFORMATORI DI ISOLAMENTO A USO ELETTRIMEDICALE

SINGLE PHASE ISOLATING TRANSFORMERS FOR THE SUPPLY OF MEDICAL LOCATION



Trasformatori con tensione primaria fino a 1000V
 e secondaria fino a 250V
 Impregnati in resina
 Avvolgimenti in rame cl.H
 Schermo elettrostatico
 Isolamento cl.F
 Isolamento tra primario e secondario doppio o rinforzato
 Morsetti di nostro brevetto
 Tensione di isolamento 4 KV
 A richiesta sonde termiche
 Frequenza 50-60Hz
 Servizio continuo
 Ogni trasformatore è testato singolarmente e corredato di scheda tecnica

*Transformers with primary voltage up to 1000V
 and secondary voltage up to 250V
 Resin insulation
 Winding in copper class H
 Electric shield
 Insulation class F
 Insulation between the input and output winding consist in double or reinforced insulation
 Terminal of our patent
 Insulation voltage 4 KV
 Thermal probe on request
 Frequency 50-60 Hz
 Continuous service
 Every transformer is tested and sell with data sheet*



**NORME CEI EN 61558 2-15
 EUROPEAN STANDARD EN 61558 2-15**

POTENZA		DIMENSIONI			FORI		FISSAGGIO	PESO
POWER		DIMENSION			FIXING	HOLES		WEIGHT
VA	L	P	H	A	B	Kg		
3000	192	190	205	145	155	26		
3500	240	210	310	205	125	28		
4000	240	230	310	205	140	31		
5000	240	240	310	205	150	34		
6300	240	250	310	205	160	38		
8000	240	270	310	205	180	41		
10000	240	290	310	205	200	46		

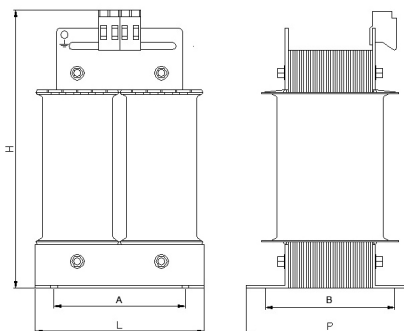

MAINETTI
 trasformatori

Via Verzano, 4 Tel.0302681112
 25131 Brescia
 email : info@mainetti.it
 mainettitransformatori@pec.it
 web : www.mainetti.it

AUTOTRASFORMATORI MONOFASE

A1

SINGLE PHASE AUTOTRANSFORMERS



Trasformatori con tensione fino a 1000V
 Impregnati in resina
 Avvolgimenti in rame cl.H
 A richiesta schermo elettrostatico
 Isolamento cl.B a richiesta cl.F
 Morsetto di terra
 Morsetti di nostro brevetto indicanti tipo di tensione
 tramite codice colori
 Tensione di isolamento 4 KV
 A richiesta sonde termiche
 Frequenza 50-60Hz
 Servizio continuo
 A richiesta tropicalizzati
 A richiesta morsetto portafusibile
 Ogni trasformatore è testato singolarmente e
 corredato di scheda tecnica

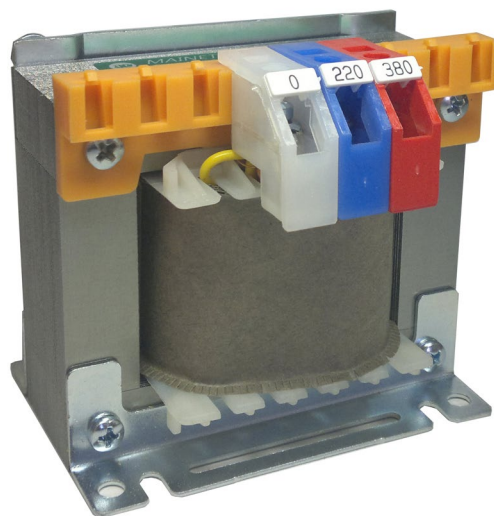

*Transformers with voltage up to 1000V
 Resin insulation
 Winding in copper class H
 Electric shield on request
 Insulation class B, class F on request
 Ground terminal
 Terminal of our patent that identify the different
 voltage by a colour code.
 Insulation voltage 4 KV
 Thermal probe on request
 Frequency 50-60 Hz
 Continuous service
 Tropicalized on request
 Terminal with fuse on request
 Every transformer is tested and sell with data sheet*

**NORME CEI EN 61558 2-13
 EUROPEAN STANDARD EN 61558 2-13**

POTENZA		DIMENSIONI			FORI		FISSAGGIO	PESO
POWER		DIMENSION			FIXING	HOLES		WEIGHT
VA	L	P	H	A	B	Kg		
100	75	80	66	55	55	0,9		
160	84	90	75	60	60	1,0		
200	84	100	75	60	70	1,2		
250	96	95	90	85	62	1,4		
315	96	105	90	85	72	2,0		
400	96	105	90	85	72	3,1		
500	120	110	110	104	75	4,9		
800	120	125	110	104	90	5,7		
1000	120	140	110	104	95	6,5		
1500	150	135	135	132	82	9,2		
2000	150	145	135	132	102	12		
2500	150	155	135	132	112	13		
3000	192	140	205	145	100	15		
4000	192	165	205	145	110	20		
5000	192	190	205	145	140	27		
6300	192	210	205	145	150	28		
8000	240	210	310	205	125	29		
10000	240	230	310	205	140	31		
12500	240	240	310	205	150	34		
16000	240	250	310	205	160	38		
20000	240	270	310	205	180	41		
25000	320	220	410	205	170	62		

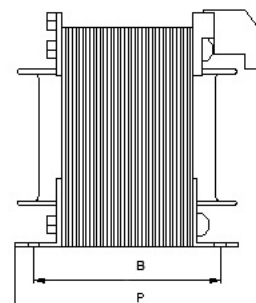
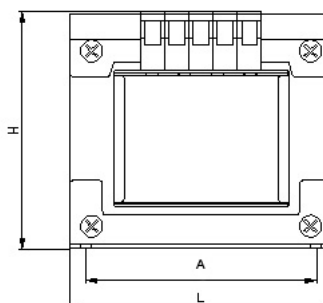

MAINETTI
trasformatori

Via Verzano, 4 Tel.0302681112
 25131 Brescia
 email : info@mainetti.it
 mainettitrasformatori@pec.it
 web : www.mainetti.it

TRASFORMATORI TRI-MONOFASE

T23

THREE-SINGLE PHASE TRANSFORMERS

Trasformatori con ingresso trifase e uscita monofase
 Trasformatori con tensione fino a 1000V
 Impregnati in resina
 Avvolgimenti in rame cl.H
 A richiesta schermo elettrostatico
 Isolamento cl.B a richiesta cl.F
 Morsetto di terra
 Tensione di isolamento 4 KV
 A richiesta sonde termiche
 Frequenza 50-60Hz
 Servizio continuo
 A richiesta tropicalizzati
 A richiesta morsetto portafusibile
 Ogni trasformatore è testato singolarmente e
 corredato di scheda tecnica



Transformers with a three phase input and single phase output

Transformers with voltage up to 1000V

Resin insulation

Winding in copper class H

Electric shield on request

Insulation class B, class F on request

Ground terminal

Insulation voltage 4 KV

Thermal probe on request

Frequency 50-60 Hz

Continuous service

Tropicalized on request

Terminal with fuse on request

Every transformer is tested and sell with data sheet

**NORME CEI EN 61558 2-4
 EUROPEAN STANDARD EN 61558 2-4**

POTENZA	DIMENSIONI			FORI	FISSAGGIO	PESO
POWER	DIMENSION			FIXING	HOLES	WEIGHT
VA	L	P	H	A	B	Kg
1000	240	130	220	200	90	10
2000	240	160	220	200	120	13
3000	300	150	270	250	110	16
4000	360	210	305	325	125	20
6000	360	240	305	325	145	30
8000	360	240	305	325	155	40
10000	360	240	305	325	165	50
12000	480	260	405	440	170	60
16000	480	270	405	440	200	70
20000	480	270	405	440	210	80
25000	480	280	405	440	220	100

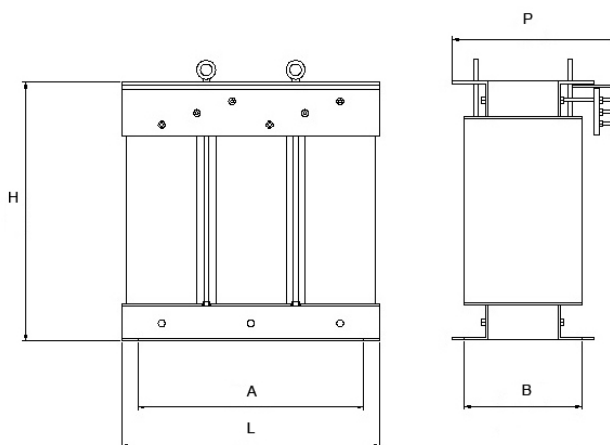

MAINETTI
 trasformatori

Via Verziano, 4 Tel.0302681112
 25131 Brescia
 email : info@mainetti.it
 mainettitrasformatori@pec.it
 web : www.mainetti.it

TRASFORMATORI TRIFASE

T3

THREE PHASE TRANSFORMERS



**NORME CEI EN 61558 2-4 EN 60076-11
EUROPEAN STANDARD EN 61558 2-4 EN 60076-11**

Trasformatori con tensione fino a 1000V
 Impregnati in resina
 Avvolgimenti in rame cl.H
 A richiesta schermo elettrostatico
 Isolamento cl.B a richiesta cl.F
 Morsetto di terra
 Morsetti di nostro brevetto (in base alla potenza)
 Tensione di isolamento 4 KV
 A richiesta sonde termiche
 Frequenza 50-60Hz
 Servizio continuo
 A richiesta tropicalizzati
 A richiesta fusibili o altre protezioni
 Ogni trasformatore è testato singolarmente e
 corredato di scheda tecnica

*Transformers with voltage up to 1000V
 Resin insulation
 Winding in copper class H
 Electric shield on request
 Insulation class B, class F on request
 Ground terminal
 Terminal of our patent (depending by the power)
 Insulation voltage 4 KV
 Thermal probe on request
 Frequency 50-60 Hz
 Continuous service
 Tropicalized on request
 Terminal with fuse or other protection on request
 Every transformer is tested and sell with data sheet*

POTENZA	DIMENSIONI			FORI	FISSAGGIO	PESO
POWER	DIMENSION			FIXING	HOLES	WEIGHT
VA	L	P	H	A	B	Kg
315	180	100	155	150	65	5,5
500	180	110	155	150	75	7,0
800	180	120	155	150	85	10
1000	240	130	220	200	90	13
1500	240	150	220	200	110	20
2000	240	160	220	200	120	22
2500	300	140	270	250	100	26
3000	300	150	270	250	110	30
4000	360	210	305	325	125	35
5000	360	220	305	325	135	40
6300	360	240	305	325	155	45
8500	360	240	305	325	145	50
10000	360	240	305	325	165	60
12500	480	270	405	440	170	70
16000	480	280	405	440	200	80
20000	480	280	405	440	200	90
25000	480	280	405	440	220	100
31500	480	280	405	440	200	110
40000	480	280	405	440	200	120
50000	600	290	505	540	230	130
63000	600	300	505	540	240	140
80000	700	270	505	540	250	150
100000	700	280	505	540	260	160
150000	800	350	650	640	300	200
200000	800	450	650	640	400	250
250000	1000	500	650			300
300000	1200	600	1000			400
350000	1200	700	1000			600
400000	1500	800	1000			900
500000	1500	800	1000			1200

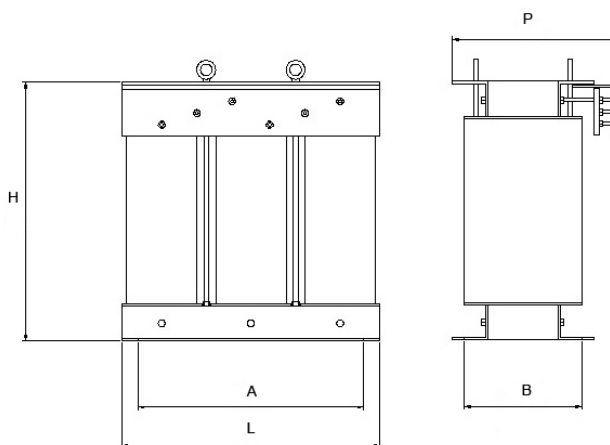

MAINETTI
trasformatori

Via Verzano, 4 Tel.0302681112
 25131 Brescia
 email : info@mainetti.it
 mainettitrasformatori@pec.it
 web : www.mainetti.it

TRASFORMATORI TRIFASE PER FOTOVOLTAICO

TF3 THREE PHASE TRANSFORMERS FOR PHOTOVOLTAIC SYSTEM



**NORME CEI EN 61558 2-4 EN 60076-11
EUROPEAN STANDARD EN 61558 2-4 EN 60076-11**

Trasformatori con tensione fino a 1000V
 Altissimo rendimento
 Impregnati in resina
 Avvolgimenti in rame cl.H
 A richiesta schermo elettrostatico
 Isolamento cl.F
 Morsetto di terra
 Collegamento tipico Yy0
 Tensione di isolamento 4 KV
 A richiesta sonde termiche
 Frequenza 50-60Hz
 Servizio continuo
 A richiesta fusibili o altre protezioni
 Ogni trasformatore è testato singolarmente e
 corredato di scheda tecnica

*Transformers with voltage up to 1000V
 High efficiency
 Resin insulation
 Winding in copper class H
 Electric shield on request
 Insulation class F
 Ground terminal
 Terminal of our patent (depending by the power)
 Typical connection Yyo
 Insulation voltage 4 KV
 Thermal probe on request
 Frequency 50-60 Hz
 Continuous service
 Terminal with fuse or other protection on request
 Every transformer is tested and sell with data sheet*

POTENZA	DIMENSIONI			FORI	FISSAGGIO	PESO
POWER	DIMENSION			FIXING	HOLES	WEIGHT
VA	L	P	H	A	B	Kg
5000	360	220	305	325	135	40
6300	360	240	305	325	155	45
8500	360	240	305	325	145	50
10000	360	240	305	325	165	60
12500	480	270	405	440	170	70
16000	480	280	405	440	200	80
20000	480	280	405	440	200	90
25000	480	280	405	440	220	100
31500	480	280	405	440	200	110
40000	480	280	405	440	200	120
50000	600	290	505	540	230	130
63000	600	300	505	540	240	140
80000	700	270	505	540	250	150
100000	700	280	505	540	260	160
150000	800	350	650	640	300	200
200000	800	450	650	640	400	250
250000	1000	500	650			300
300000	1200	600	1000			400
350000	1200	700	1000			600
400000	1500	800	1000			900
500000	1500	800	1000			1200

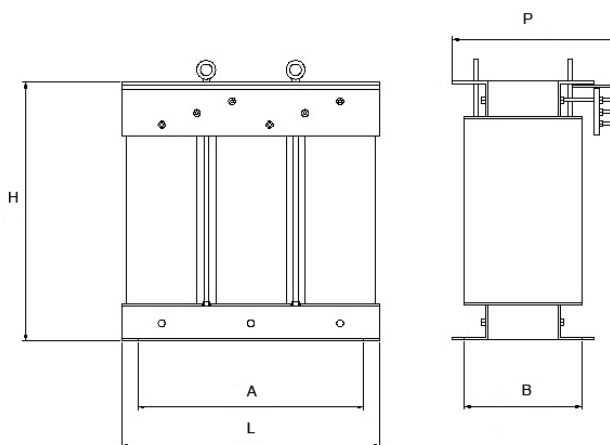

MAINETTI
trasformatori

Via Verziano, 4 Tel.0302681112
 25131 Brescia
 email : info@mainetti.it
 mainettitrasformatori@pec.it
 web : www.mainetti.it

AUTOTRASFORMATORI TRIFASE

A3

THREE PHASE AUTOTRANSFORMERS

Trasformatori con tensione fino a 1000V
 Impregnati in resina
 Avvolgimenti in rame cl.H
 A richiesta schermo elettrostatico
 Isolamento cl.B a richiesta cl.F
 Morsetto di terra
 Morsetti di nostro brevetto
 Tensione di isolamento 4 KV
 A richiesta sonde termiche
 Frequenza 50-60Hz
 Servizio continuo
 A richiesta tropicalizzati
 A richiesta fusibili o altre protezioni
 Ogni trasformatore è testato singolarmente e
 corredato di scheda tecnica

*Transformers with voltage up to 1000V
 Resin insulation
 Winding in copper class H
 Electric shield on request
 Insulation class B, class F on request
 Ground terminal
 Terminal of our patent
 Insulation voltage 4 KV
 Thermal probe on request
 Frequency 50-60 Hz
 Continuous service
 Tropicalized on request
 Terminal with fuse or other protection on request
 Every transformer is tested and sell with data sheet*

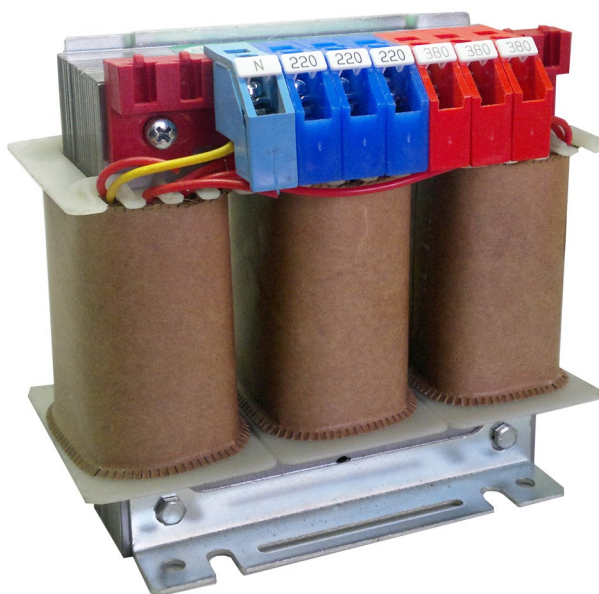

**NORME CEI EN 61558 2-13 EN 60076-11
 EUROPEAN STANDARD EN 61558 2-13 EN 60076-11**

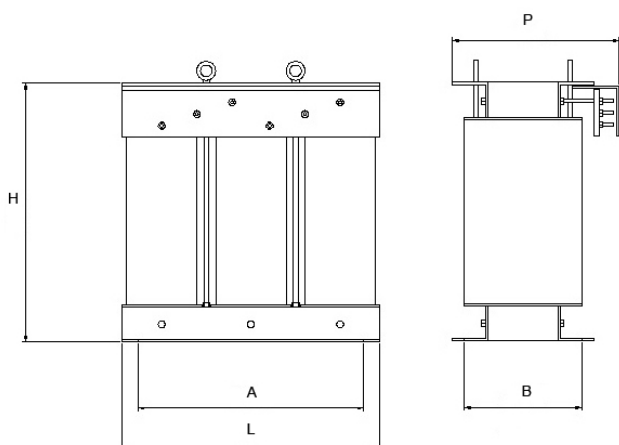

POTENZA	DIMENSIONI			FORI	FISSAGGIO	PESO
POWER	DIMENSION			FIXING	HOLES	WEIGHT
VA	L	P	H	A	B	Kg
500	160	90	135	132	62	5
1000	180	100	160	150	65	6
1500	180	110	160	150	75	9
2000	180	110	160	150	75	13
2500	180	120	160	150	85	14
3000	180	135	160	150	100	18
4000	240	150	210	200	105	20
5000	240	160	210	200	115	23
6300	240	160	210	200	115	24
8500	300	150	260	250	100	30
10000	300	160	260	250	110	32
12500	300	180	260	250	130	35
16000	360	240	305	325	135	40
20000	360	260	305	325	155	50
25000	360	280	305	325	175	68
31500	480	260	405	440	180	77
40000	480	290	405	440	190	88
50000	480	320	405	440	200	94
63000	480	330	405	440	210	116
80000	600	280	505	540	190	125
100000	600	300	505	540	200	170
160000	600	320	505			240
200000	700	310	620			310
250000	700	320	620			380
315000	700	450	620			460
400000	1000	480	870			520
500000	1000	480	870			680



MAINETTI
 trasformatori

Via Verziano, 4 Tel.0302681112
 25131 Brescia
 email : info@mainetti.it
 mainettitrasformatori@pec.it
 web : www.mainetti.it

REATTANZE TRIFASE

Z3

THREE PHASE REACTORS

Utilizzate per avviamento motori asincroni trifase
 Tensione 400 V (altre a richiesta)
 Tensione di isolamento 4KV
 Impregnate in resina
 Avvolgimenti in rame cl.H
 Isolamento cl.B a richiesta cl.F
 Morsetto di terra
 Frequenza 50-60Hz
 Grado di protezione IP00
 Possibilità di montaggio orizzontale
 A richiesta sonde termiche



*Used for starting three phase asynchronous motor
 Voltage 400 V (other on request)
 Insulation voltage 4KV
 Resin insulation
 Winding in copper class H
 Insulation class B, class F on request
 Ground terminal
 Thermal probe on request
 Frequency 50-60 Hz
 IP00
 On request horizontal mounting
 Thermal probe on request*

**NORME CEI EN 61558 2-20 EN 60289
 EUROPEAN STANDARD EN 61558 2-20 EN 60289**

POTENZA		FORI		FISSAGGIO	PESO
POWER		FIXING		HOLES	WEIGHT
KW	HP	A	B		Kg
2,9	4	132	65	5	
5,1	7	150	65	7,8	
5,9	8	150	75	10	
7,4	10	150	75	11	
11	15	150	80	12	
15	20	150	85	13	
18	25	150	90	14	
22	30	210	130	17	
29	40	210	130	20	
37	50	210	130	23	
44	60	260	130	30	
51	70	260	185	35	
59	80	260	230	40	
74	100	310	230	60	
88	120	310	285	65	
110	150	310	285	75	
132	180	310	285	85	
147	200	310	285	98	
184	250	310	285	115	
221	300	440	340	130	
257	350	560	340	140	

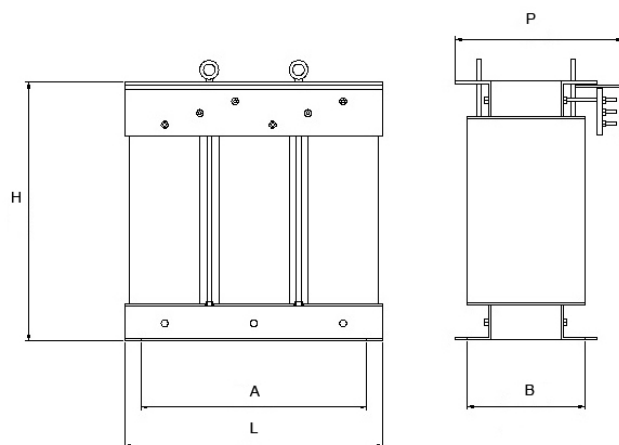

MAINETTI
 trasformatori

Via Verziano, 4 Tel.0302681112
 25131 Brescia
 email : info@mainetti.it
 mainettitrasformatori@pec.it
 web : www.mainetti.it

ARMADI DI CONTENIMENTO

BOX

PROTECTIVE CABINETS

Armadi in lamiera verniciata a scelta secondo colori RAL
Grado di protezione IP 23
Alettature per permettere migliore raffreddamento
Ingresso cavi inferiormente al box
Griglia anti topo
Pannelli laterali superiori e frontali completamente amovibili.
Base portante
Dimensioni diverse a richiesta

*Box in steel paint in any RAL colour
IP 23*

The box has holes for a better cooling

Cables enter under the box

All the panels are removable

Anti intrusion grid

Supporting base

Different dimension on request

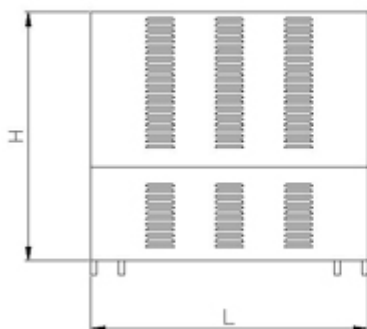

DIMENSIONI		
DIMENSION		
L	P	H
750	500	700
850	500	700
1000	600	900
1100	700	1000
1500	900	1100
2200	1500	1900



MAINETTI
trasformatori

Via Verziano, 4 Tel.0302681112
25131 Brescia
email : info@mainetti.it
mainettitrasformatori@pec.it
web : www.mainetti.it